

NEW!

The practical extras for the
BLANCO COOK front cooking system.

blancoinnovation

A little effort with a big effect:
The new BLANCO COOK table and the new BLANCO COOK containers

NEW: Height-adjustable table with
optional sneeze guard



NEW: Mobile container with
drawer and compartment



NEW: Optional panelling made
of rugged HPL

A hearty office party in a decommissioned warehouse today, a romantic wedding in the middle of a green meadow tomorrow: there is never the same use twice, especially in event catering. But everything should always be perfect anyway.

The new table and the new containers from the BLANCO COOK system make front cooking as mobile as possible.

With the new BLANCO COOK extras, you can set up a well-organised workplace for your cooking show in any environment. Fast, flexible and with sufficient room and storage space for a clean presentation in front of guests. It has a high-quality uniform appearance which exudes professionalism and conveys quality beyond the first glance.

**For your perfect presentation
in front of guests: front cooking with
the BLANCO COOK system.**

Fast set-up, fast dismantling, everything is handy and under control.

With the new extras from the BLANCO COOK front cooking system, you can now adapt your cooking show even better to the changing conditions on site and the various food concepts.

The fume extraction module reliably removes grease, moisture and undesirable odours from the cooking vapours. The table-top cooking units shine with high-quality technology, extremely short heat-up times and high energy efficiency. The new extras and extensive accessories complement the system perfectly.

Easy to transport, simple to handle and versatile without limits:

The BLANCO COOK system makes optimum performance possible for professionals – anytime and anywhere.

BLANCO COOK table for setting down dishes, arranging food and serving.

- » Fast set-up and dismantling, no tools required.
- » Only 65 mm high when dismantled and stackable on europallets – perfect for space-saving storage and transport.
- » Can be used free-standing or hooked into the BLANCO COOK fume extraction module – for a uniform appearance and stable footing.
- » With an optional sneeze guard, the table can be hygienically used as a serving surface.
- » Optional shelf for even more surface for storing and clearing away dishes.

BLANCO COOK containers for stowing, transporting and storing.

- » Compact and mobile.
- » Versatile use as storage space, work surface and storage surface.
- » Drawer for convenient work thanks to its full extension and soft closing.
- » Euro boxes (400 x 600 mm) fit perfectly in the compartment.
- » With the optional GN supports, up to eight GN-1/1 containers can be stored in the compartment in a secure and space-saving way.
- » The optional steel screen basket can be hooked into the inside of the compartment door, ideal for a waste container, for example.



Attractive and impressive.

Full functionality for the chef, an attractive appearance for the guests: the optional panelling for the table and containers can be mounted quickly and easily. Also perfect for self-promotion – have the panelling decorated with your logo or other design of your choice by an advertising professional.*

Versatile, changeable, individual: Front cooking with the BLANCO COOK system.

Whether set up in a line or planned around the corner, BLANCO COOK adapts to your requirements. All the elements have the exact same height and depth. This ensures you the highest

possible degree of flexibility in setting up and organising working and rear areas.

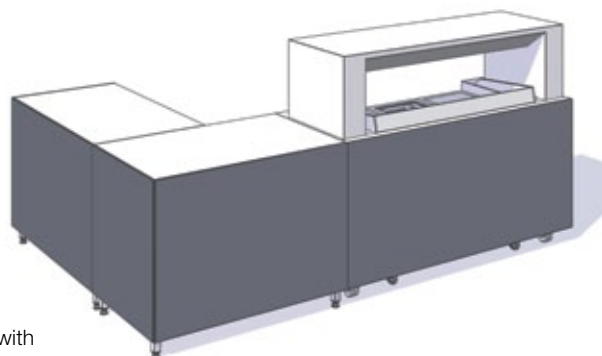
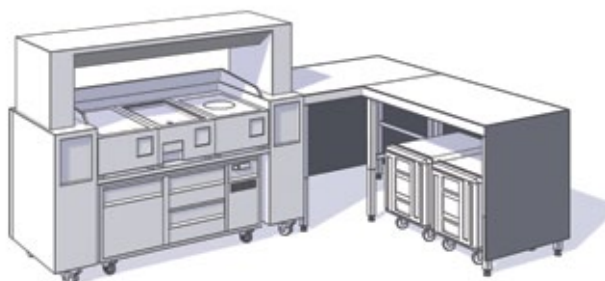

Application example 1: Practical corner combination of two BLANCO COOK tables with plenty of room for setting down dishes and serving. Food can be stored temporarily in the BLANCOTHERM food transport containers located below. The cooling table beneath the BLANCO COOK fume extraction module keeps refrigerated food and ingredients fresh.

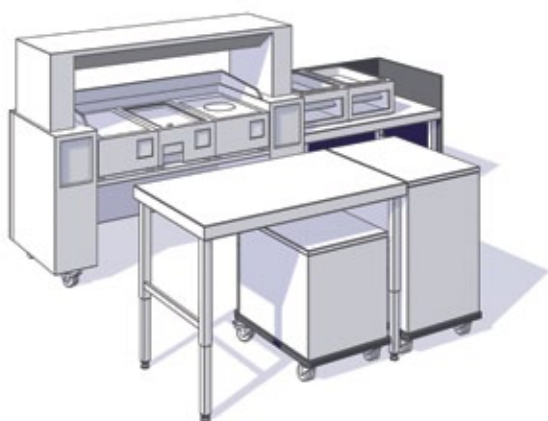

Application example 2: Plenty of storage space and storage surface in the rear area with the table and two containers from BLANCO COOK. Two multi-elements provide handy ingredients and pots and pans on the right next to the fume extraction module.

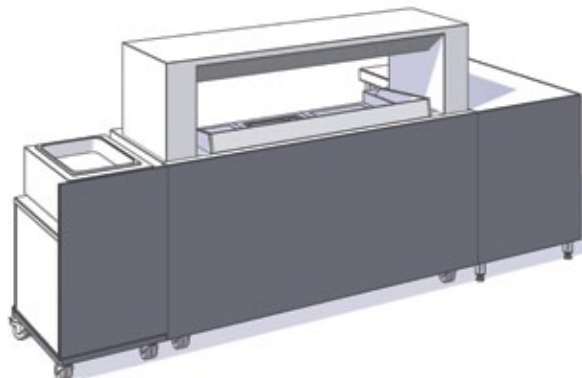
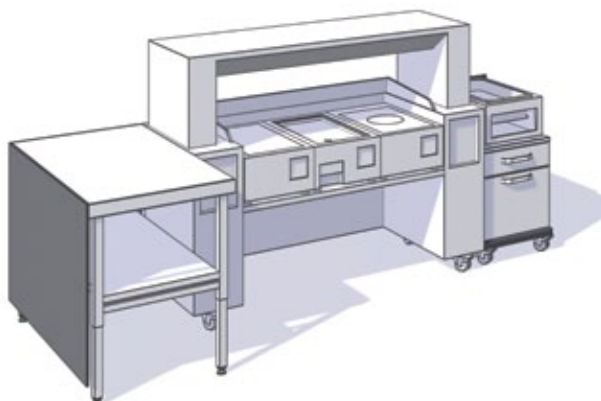

Application example 3: The low container BC CO 660 with the multi-element placed on top of it offers many possibilities in an extremely small space. With the optional shelf, a lot can also be stored beneath the table.

**Clever and smart:
The new extras from the BLANCO COOK system.**



| Model | BC T | BC CO 660 | BC CO 900 |
|----------------------------|--|---|---|
| Designation | BLANCO COOK table | BLANCO COOK container 660 | BLANCO COOK container 900 |
| Model | Table with insertion feet adjustable to four variable heights | Mobile container (660 mm high) with 1 drawer and 1 compartment | Mobile container (900 mm high) with 1 drawer and 1 compartment |
| Dimensions / weight | W x D: 1180 x 700 mm H: 660/720/900/960 mm Weight approx. 20 kg | W x D x H: 507 x 690 x 660 mm Weight approx. 36 kg | W x D x H: 507 x 745 x 900 mm Weight approx. 40 kg |
| Capacity | Usable space beneath the table W x D x H: 1045 x 700 x 836 mm (for table height of 900 mm), for example for 2 containers BC CO 600 or 2 BLT 420 K with dolly 100 or dolly 125 or 2 BLT 620 K with dolly 100 Max. loading capacity: approx. 100 kg | Interior dimensions drawer W x D x H: 364 x 580 x 110 mm Interior dimensions compartment W x D x H: 419 x 624 x 472 mm | Interior dimensions drawer W x D x H: 364 x 580 x 110 mm Interior dimensions compartment W x D x H: 419 x 679 x 712 mm |
| Equipment | Insertion feet mechanically adjustable to four heights Cable opening in the table top for Schuko and CEE plugs (incl. synthetic cover cap) Securing holes to directly hook into the BLANCO COOK fume extraction module Retainers on the long and short sides for optional panelling | Drawer made of ABS with full extension and soft closing Compartment suitable to accept baskets and boxes of the size 400 x 600 mm (euro boxes) All-round bumper rail Removable transportation security for drawer and compartment Solid synthetic casters with a diameter of 75 mm: 4 steering castors, 2 of which have brakes Retainer for optional GN supports in compartment Retainer for optional steel screen basket on the inside of the door | Drawer made of ABS with full extension and soft closing Compartment suitable to accept baskets and boxes of the size 400 x 600 mm (euro boxes) All-round bumper rail Removable transportation security for drawer and compartment Solid synthetic casters with a diameter of 75 mm: 4 steering castors, 2 of which have brakes Retainer for optional GN supports in compartment Retainer for optional steel screen basket on the inside of the door Retainer for optional shelf in the compartment |
| Accessories | See page on the right | See page on the right | See page on the right |
| Material | Stainless steel CNS 18/10 (Material No. 1.4301) with micro-polished surface | Stainless steel CNS 18/10 (Material No. 1.4301) with micro-polished surface | Stainless steel CNS 18/10 (Material No. 1.4301) with micro-polished surface |
| Order No. | 573 589 | 573 587 | 573 588 |

* The "Gourmet Catering" logo illustrated serves only as an example of individually applied decals. The panelling is supplied without a logo entirely in the colour "ebony" RAL 10622-60. BLANCO CS cannot produce your design for technical reasons. Please contact your local signmaker or labelling expert for this service.

accessories/options

Accessories and options for the extras from the BLANCO COOK system

| Designation | Description | For models | Model / Note | Order No. |
|----------------------------|--|------------------------|---|---|
| Panelling | Material: HPL, colour: ebony (RAL 10622-60), Material thickness: 4 mm | BC T | Long side, Dimensions: 1180 x 795 mm | 573 590 |
| | | | Short side, Dimensions: 700 x 795 mm | 573 591 |
| | The panelling made of HPL is also available for the BLANCO COOK fume extraction module BC ES 2 and BC ES 3. | BC CO 660 BC CO 900 | Customer side, Dimensions: 487 x 764 mm | 573 592 |
| | | | BC ES 2 BC ES 3 | Customer side, Dimensions for BC ES 2: 1322 x 795 mm, Dimensions for BC ES 3: 1727 x 795 mm |
| Sneeze guard | CNS attachment with a plexiglass window, closed on the customer side, without a pass-through, fastening using integrated magnets | BC T | Dimensions: 1145 x 250 x 456 mm | 573 593 |
| Shelf | Made of CNS (can be combined with GN supports in container BC CO 900) | BC CO 900 | Dimensions: 417 x 675 x 24 mm | 573 595 |
| | | BC T | Dimensions: 1145 x 620 x 30 mm | 573 596 |
| Steel screen basket | Powder-coated, white | BC CO 660 | Capacity: 18 litres, Dimensions: 302 x 306 x 207 mm | 573 585 |
| | | BC CO 900 | Capacity: 26 litres, Dimensions: 305 x 446 x 195 mm | 573 584 |
| GN support | Made of CNS, to place into the compartment of the container (can be combined with shelf in container BC CO 900), Capacity: 4 x GN 1/1-65 or 8 x GN 1/1-20 | BC CO 660 BC CO 900 | Dimensions: 416 x 545 x 330 mm | 573 586 |
| Lock | For the drawer of the container | BC CO 660 BC CO 900 | -- | Optional |
| Castors | Synthetic castors with a diameter of 125 mm: 4 steering castors, 2 of which have brakes, corrosion-resistant pursuant to DIN 18867-8 | BC CO 660 BC CO 900 | Because of the larger castor diameter, the total height of the containers is thus 720 or 960 mm | Optional |
| | Stainless steel castors with a diameter of 125 mm: 4 steering castors, 2 of which have brakes, corrosion-resistant pursuant to DIN 18867-8 | BC CO 660 BC CO 900 | | Optional |

www.blanco-catering.eu

We will be happy to provide you with additional information on the BLANCO COOK front cooking system and our product line free of charge (see reverse side). You can also simply visit us on the Internet at www.blanco-catering.eu

Expand your possibilities: Maximum flexibility with the BLANCO COOK system.

With the extensive accessories and supplemental products from the entire BLANCO product line, a suitable solution can always be found for your perfect cooking show.



You are perfectly equipped for transporting food securely and storing it at just the right temperature with the optimally insulated BLANCOTHERM K food transport containers.

Depending on whether you want to place the containers beneath the extraction module or under a table, you can use the models of the 420 or 620 series with the respective dolly.

The models 420 KBRUH and 620 KBRUH can be regulated down to the degree and can even be used for low-temperature cooking – perfect for the preparation of tender meat.



Practically well refrigerated: the underframe cooling table keeps ingredients appetisingly fresh. Reliable compliance with the cooling temperatures required by HAACP is possible with it, even for mobile front cooking.

The underframe cooling table for the BLANCO COOK fume extraction module BC ES 3 is available in several designs.



Essential assistants for any professional: the premium Gastronorm containers from BLANCO. Whether made of stainless steel or synthetic, perforated or smooth, with handles or without, with a lid or without – high-quality material and exact finishing ensure an extra-long service life.

Over 50 years of experience in the manufacture of GN containers vouch for the unmistakable BLANCO quality.

BLANCO CS GmbH + Co KG
Catering Systems
P.O. Box 13 10
75033 OBERDERDINGEN
GERMANY
Phone +49 7045 44-81900
Fax +49 7045 44-81481
Internet www.blanco.de
E-Mail catering.export@blanco.de

BLANCO

